



US 20040169460A1

(19) **United States**

(12) **Patent Application Publication**

**Chang et al.**

(10) **Pub. No.: US 2004/0169460 A1**

(43) **Pub. Date:**

**Sep. 2, 2004**

(54) **ACTIVE MATRIX ORGANIC LIGHT  
EMITTING DISPLAY AND METHOD OF  
FORMING THE SAME**

(52) **U.S. Cl.** ..... 313/498; 313/499

(76) **Inventors: Shih-Chang Chang, Hsinchu (TW);  
Hsiu-Chun Hsieh, Changhua City  
(TW); Yaw-Ming Tsai, Taichung Hsien  
(TW)**

(57) **ABSTRACT**

An active matrix organic light emitting display and a method of forming the same. The AM-OLED including a substrate with a plurality of thin film transistors serving as driver circuits, a dielectric layer formed conformally on the substrate and the thin film transistors, a first insulating layer formed on parts of the dielectric layer to define the exposed surface of the dielectric layer as a predetermined transparent electrode area, a transparent electrode formed conformally on the predetermined transparent electrode area, a second insulating layer formed on both sides of the transparent electrode to expose parts of surface of the transparent electrode, an organic electroluminescent layer formed on the transparent electrode, and a metal electrode formed on the organic electroluminescent layer. The insulating layer smoothes the transparent electrode surface enhancing the luminescent characteristics of the AM-OLED.

Correspondence Address:

**LIU & LIU LLP  
811 WEST SEVENTH STREET, SUITE 1100  
LOS ANGELES, CA 90017 (US)**

(21) **Appl. No.:** 10/762,203

(22) **Filed:** Jan. 20, 2004

(30) **Foreign Application Priority Data**

Jan. 22, 2003 (TW)..... 92101326

**Publication Classification**

(51) **Int. Cl.<sup>7</sup>** ..... H05B 33/00

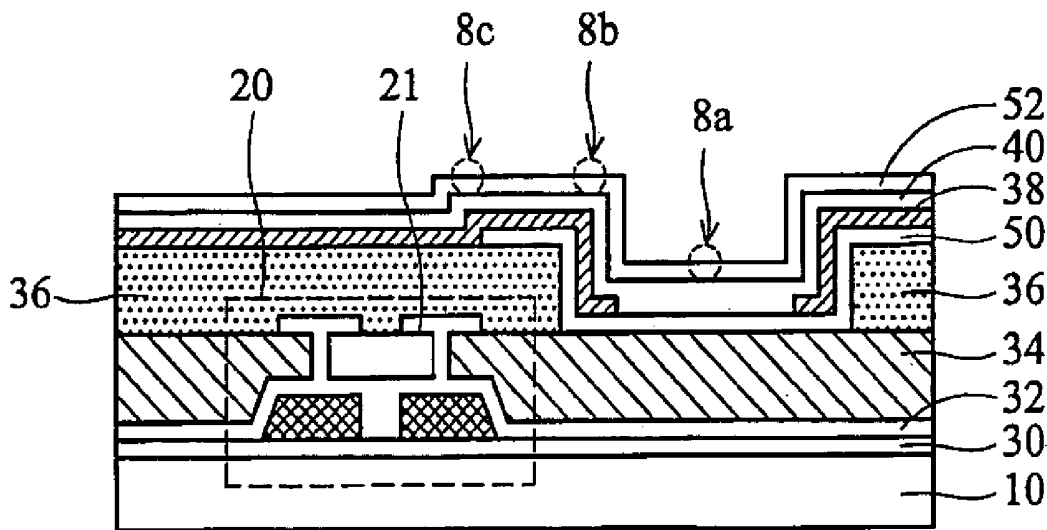

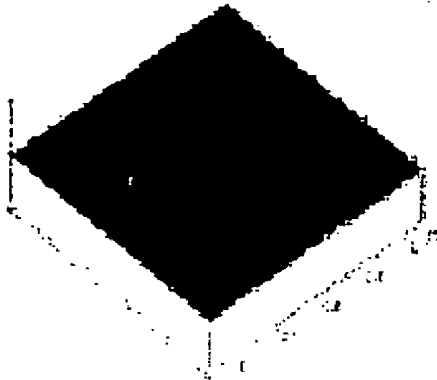

FIG. 1a

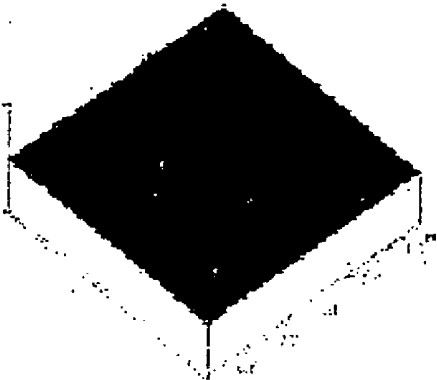

FIG. 1b

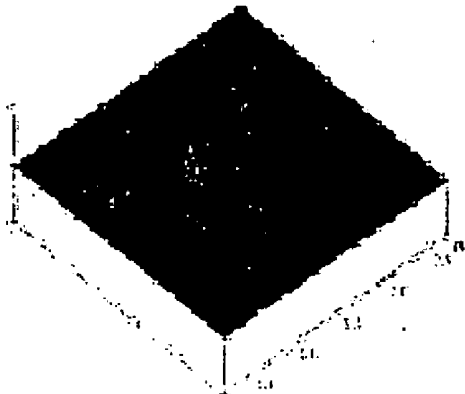

FIG. 1c

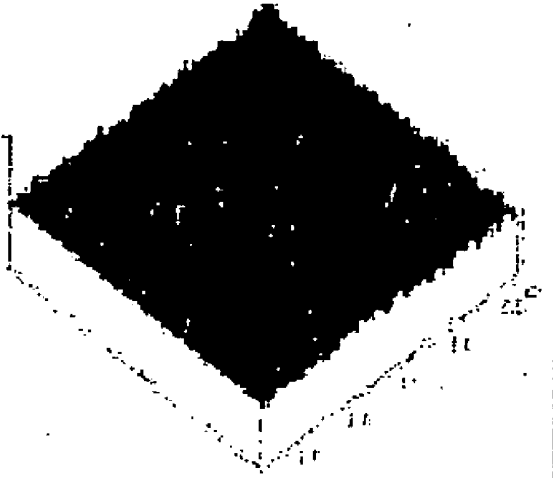

FIG. 1d

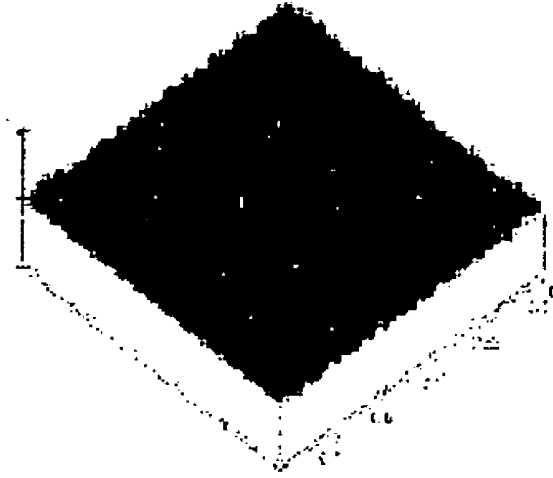

FIG. 1e

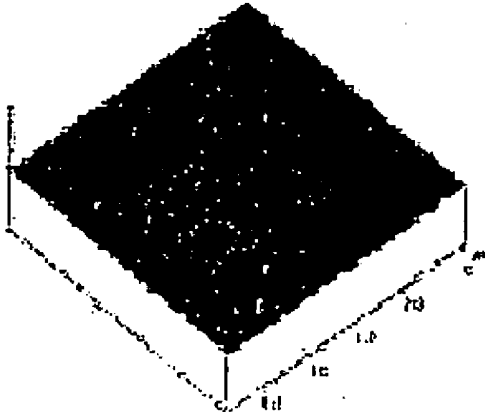

FIG. 2a

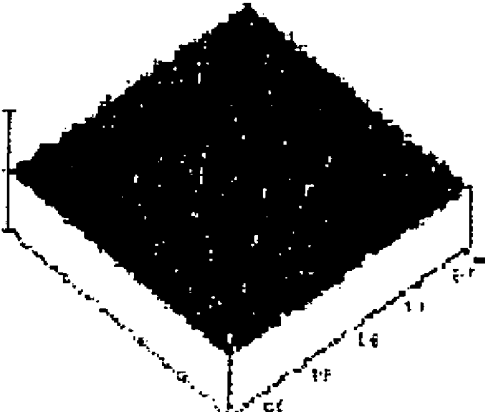

FIG. 2b

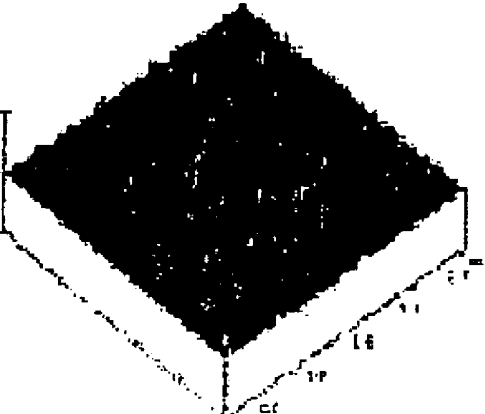

FIG. 2c

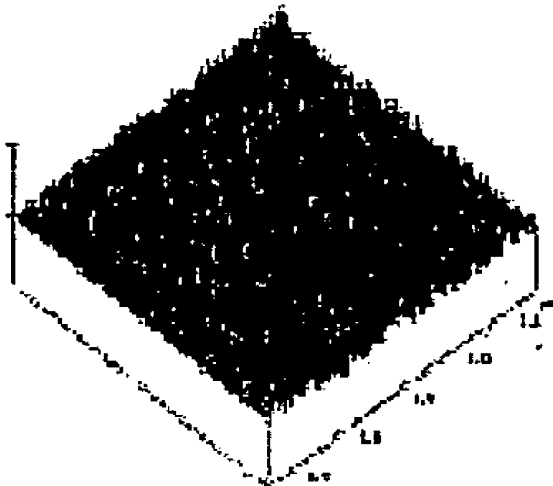

FIG. 2d



FIG. 2e

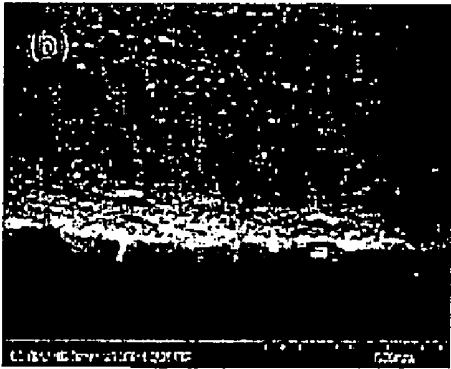

FIG. 3a

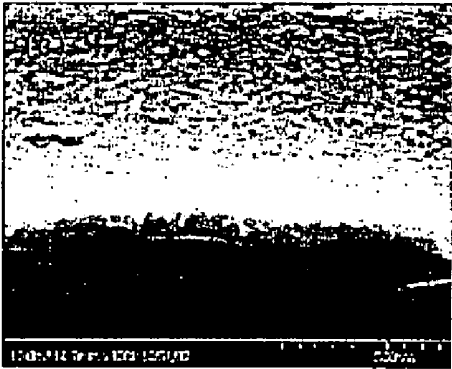

FIG. 3b

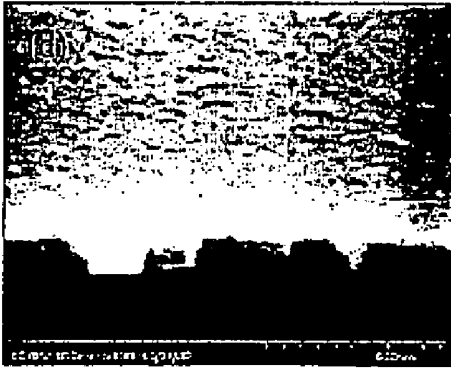

FIG. 3c



FIG. 3d

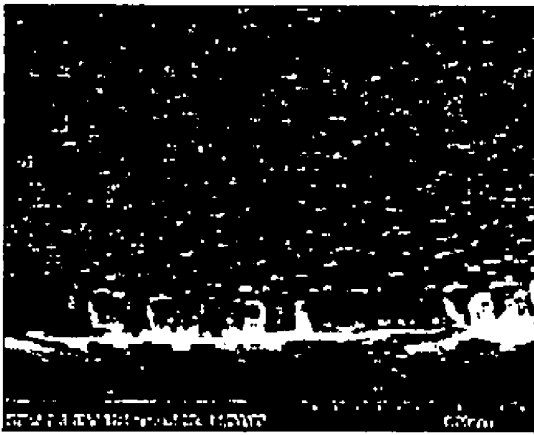

FIG. 3e



FIG. 4a

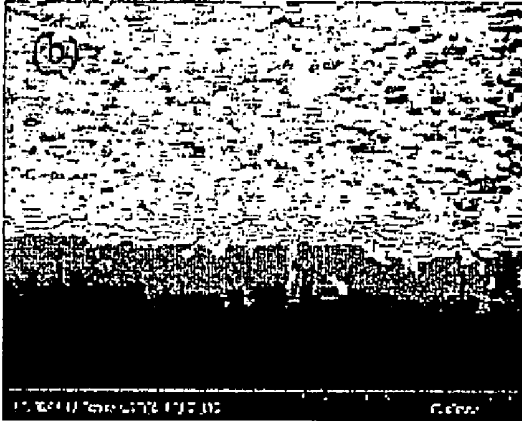

FIG. 4b



FIG. 4c

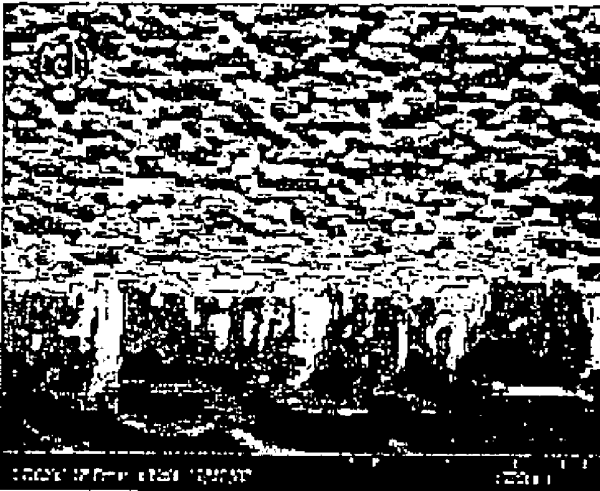

FIG. 4d

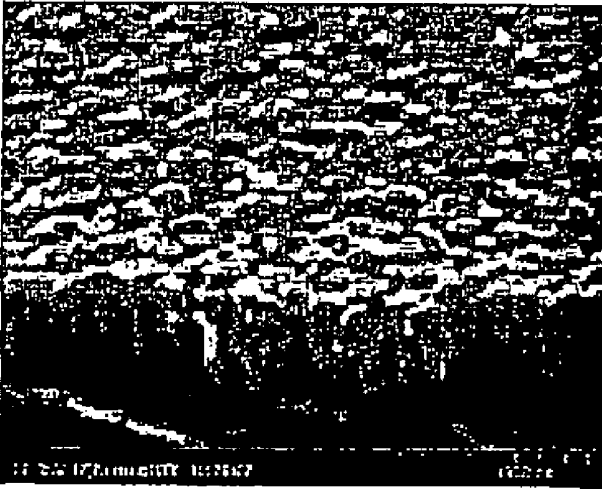

FIG. 4e

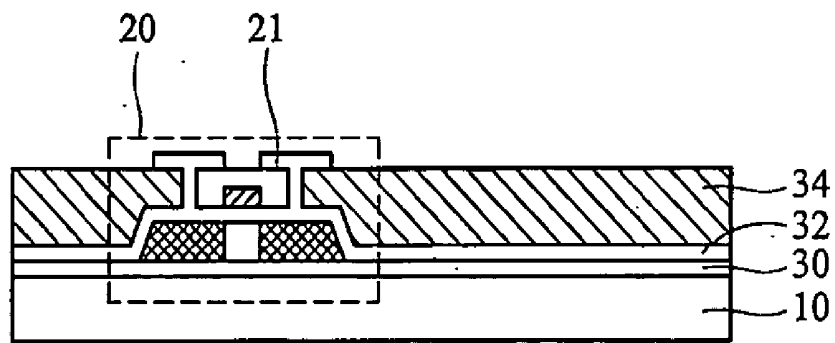

FIG. 5a

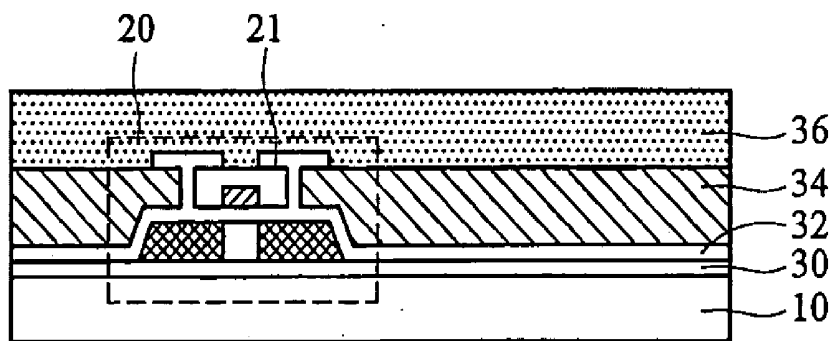

FIG. 5b

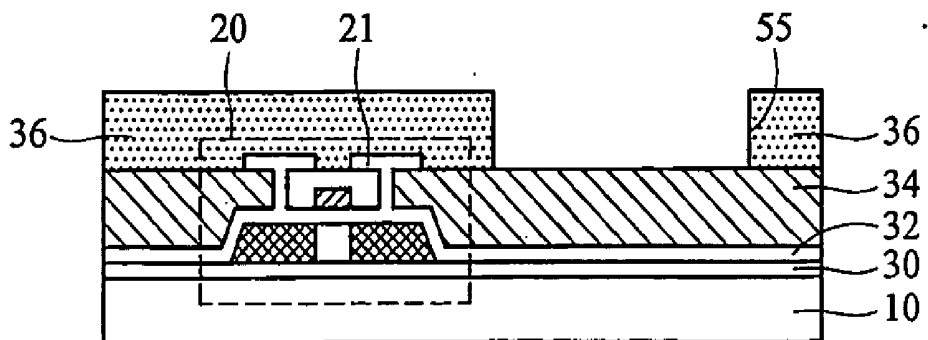

FIG. 5c

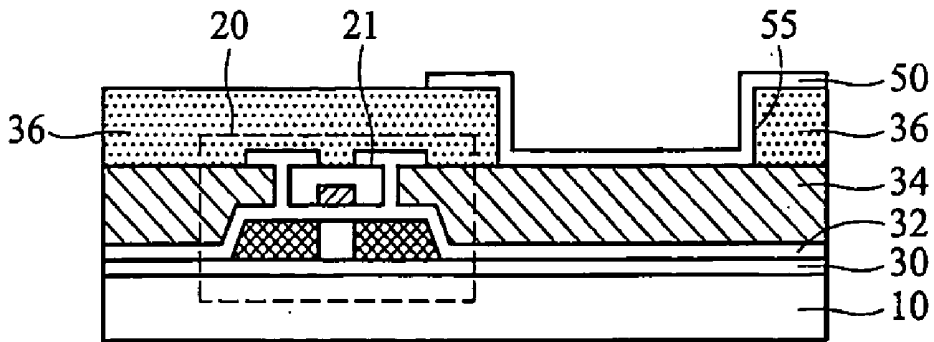

FIG. 5d

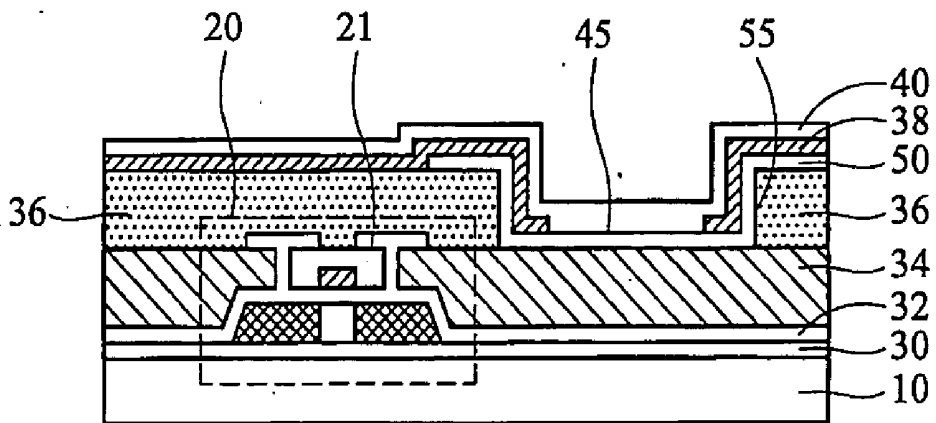

FIG. 5e

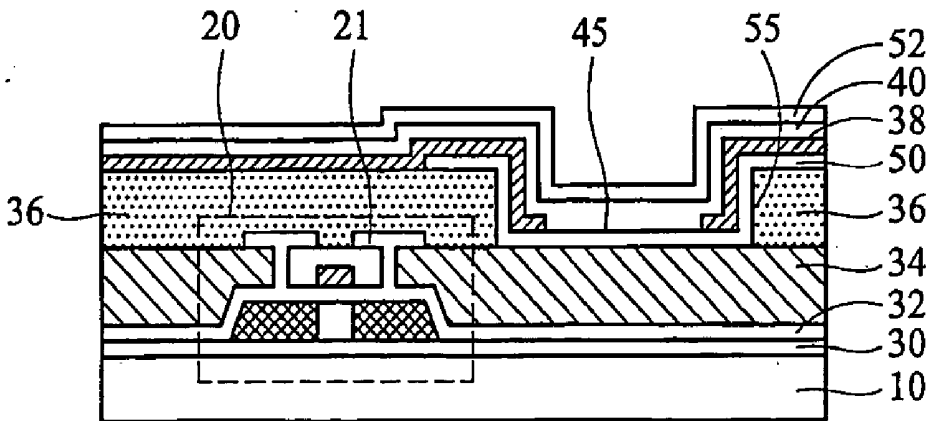

FIG. 5f

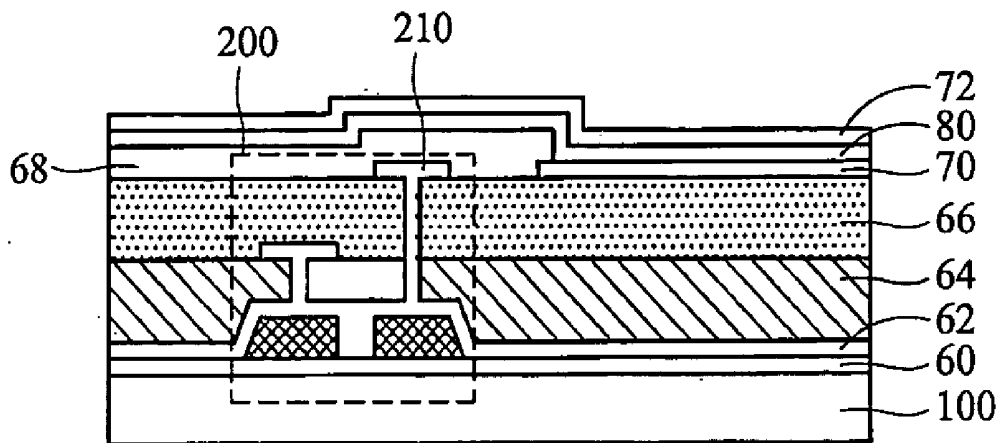

FIG. 6

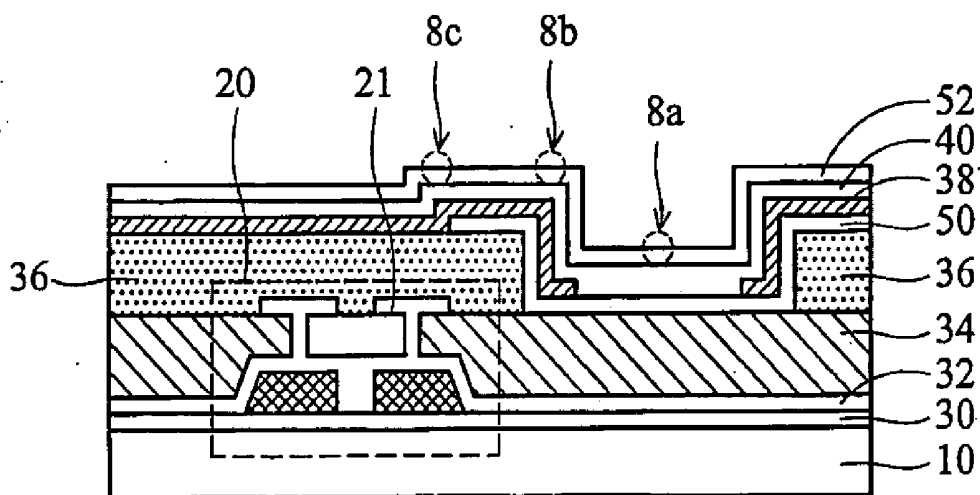

FIG. 7

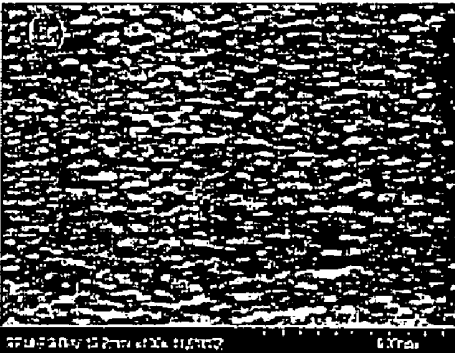

FIG. 8a

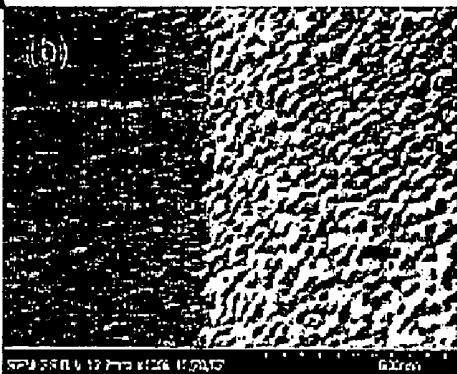

FIG. 8b

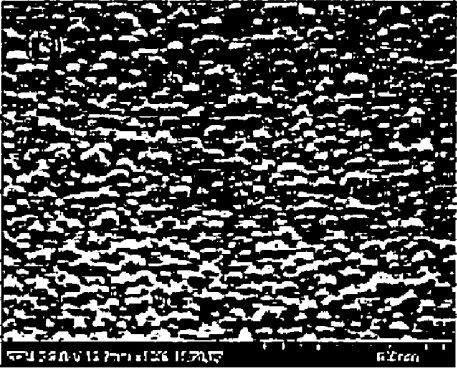

FIG. 8c

## ACTIVE MATRIX ORGANIC LIGHT EMITTING DISPLAY AND METHOD OF FORMING THE SAME

### BACKGROUND OF THE INVENTION

#### [0001] 1. Field of the Invention

[0002] The present invention relates to an active matrix organic light emitting display (AM-OLED) and, more particularly, to an AM-OLED with a dielectric layer under a transparent electrode, improving the surface of the transparent electrode.

#### [0003] 2. Description of the Related Art

[0004] In accordance with driving methods, an organic light emitting display (OLED) is an active matrix type or a positive matrix type. The active matrix OLED (AM-OLED) is driven by electric currents, in which each of the matrix-array pixel areas has at least one thin film transistor (TFT), serving as a switch, to modulate the driving current based on the variation of capacitor storage potential so as to control the brightness and gray level of the pixel areas.

[0005] Concerned with the luminescent principle of the AM-OLED, an electric current is applied to a specific organic lamination to convert electricity to luminescence. The AM-OLED has panel luminescence with thin and lightweight characteristics, spontaneous luminescence with high luminance efficiency and low driving voltage, and advantages of increased view angle, high contrast, high-response speed, full color and flexibility.

[0006] Indium tin oxide (ITO) has been widely used as anode electrode material for AM-OLED application because of its transparency, good conductivity, and high work function. Moreover, it is found that the luminescent characteristics of AM-OLED depend strongly on the surface roughness of the anode electrode. The surface roughness of ITO film must be smooth enough to avoid large leakage current or point discharge causing pixel defects.

[0007] The average roughness of ITO film formed by sputter deposition is less than 1 nm. Instead of being formed on a smooth glass plate in PM-OLED process, the ITO film is formed on an under-layer in AM-OLED process, wherein the surface roughness of ITO film depends strongly on different under-layers.

[0008] Generally, a transparent and insulating organic material is used as the under-layer in conventional AM-OLED process. However, the surface roughness of ITO film on the organic materials is 3~4 times larger than that on a smooth glass plate. The average roughness (Ra) of ITO film on the organic materials is about 3~4nm and such rough surface may result in large leakage current and cause point discharge, such that the luminance efficiency and lifetime of the device are adversely affected.

### SUMMARY OF THE INVENTION

[0009] An object of the present invention is to provide an active matrix organic light emitting display having a dielectric layer serving as an under-layer of a transparent electrode and a method of forming the same to solve the problems occurring in the prior art.

[0010] To achieve the above object, according to the present invention, an active matrix OLED (AM-OLED)

comprises a substrate with a plurality of thin film transistors serving as driver circuits, a dielectric layer formed conformally on the substrate and the thin film transistors, a first insulating layer formed on parts of the dielectric layer to define the exposed surface of the dielectric layer as a predetermined transparent electrode area, a transparent electrode formed conformally on the predetermined transparent electrode area and the surrounding surface on the first insulating layer, a second insulating layer formed on both sides of the transparent electrode to expose parts of the transparent electrode, an organic electroluminescent layer formed conformally on the transparent electrode and the second insulating layer, and a metal electrode formed on the organic electroluminescent layer.

[0011] In the present invention, the method for forming an active matrix OLED having a dielectric layer serving as an under-layer of a transparent electrode comprises the following steps.

[0012] First, a substrate with a plurality of transistors is provided. Next, a dielectric layer is formed conformally on the substrate and the transistors. A first insulating layer is formed on the dielectric layer. A first photoresist layer with an opening is formed and defined on the first insulating layer. Then, the first insulating layer is etched using the first photoresist layer as a mask to expose a part of the dielectric layer. The exposed surface of the dielectric layer serves as a predetermined transparent electrode area. Furthermore, a transparent electrode is formed conformally on the predetermined transparent electrode area. Then, a second insulating layer is formed on both sides of the transparent electrode exposing parts of the transparent electrode. An organic electroluminescent layer is formed conformally on the transparent electrode and the second insulating layer. Finally, a metal electrode is formed on the organic electroluminescent layer.

### BRIEF DESCRIPTION OF THE DRAWINGS

[0013] The present invention is more fully understood by reading the subsequent detailed description and examples with references made to the accompanying drawings, wherein:

[0014] **FIGS. 1a to 1e** are atomic force microscope (AFM) images showing the surface morphology of ITO film having a thickness of 750Å formed on different under-layers including glass plate **1a**, silicon oxide **1b**, silicon nitride **1c**, insulating organic material A (PC403, available from JSR) **1d**, and insulating organic material B (PC415, available from JSR) **1e**;

[0015] **FIGS. 2a to 2e** are atomic force microscope (AFM) images showing the surface morphology of ITO film having a thickness of 1500 Å formed on different under-layers including glass plate **2a**, silicon oxide **2b**, silicon nitride **2c**, insulating organic material A (PC403, available from JSR) **2d**, and insulating organic material B (PC415, available from JSR) , **2e**;

[0016] **FIGS. 3a to 3e** are scanning electron microscope (SEM) photographs showing the surface morphology of ITO film having a thickness of 750 Å formed on different under-layers including glass plate **3a**, silicon oxide **3b**, silicon nitride **3c**, insulating organic material A (PC403, available from JSR) **3d**, and insulating organic material B (PC415, available from JSR) **3e**;

[0017] FIGS. 4a to 4e are scanning electron microscope (SEM) photographs showing the surface morphology of ITO film having a thickness of 1500Å formed on different under-layers including glass plate 4a, silicon oxide 4b, silicon nitride 4c, insulating organic material A (PC403, available from JSR) 4d, and insulating organic material B (PC415, available from JSR) 4e;

[0018] FIGS. 5a to 5f are cross-sections illustrating the process flow of pixel structure formation for the organic light emitting display according to a preferred embodiment of the present invention;

[0019] FIG. 6 is a cross-section illustrating conventional pixel structure of the active matrix OLED;

[0020] FIG. 7 is a cross-section illustrating a pixel structure of the active matrix OLED according to a preferred embodiment of the present invention;

[0021] FIG. 8a is a scanning electron microscope (SEM) photograph showing the surface morphology of location 8a shown in FIG. 7;

[0022] FIG. 8b is a scanning electron microscope (SEM) photograph showing the surface morphology of location 8a shown in FIG. 7;

[0023] FIG. 8c is a scanning electron microscope (SEM) photograph showing the surface morphology of location 8a shown in FIG. 7.

#### DETAILED DESCRIPTION OF THE INVENTION

[0024] The present invention provide an AM-OLED having a dielectric layer in place of insulating organic material layer serving as an under-layer of a transparent electrode, lowering the average roughness (Ra) of the transparent electrode. Accordingly, the AM-OLED having a smoother transparent electrode surface can prevent large leakage current or point discharge.

[0025] The transmittances of ITO film formed on different under-layers are almost the same, compared with ITO film without any under-layer (i.e. ITO deposited on top surface of glass substrates). However, the average roughness (Ra) of ITO film depends strongly on the under-layer material.

[0026] ITO film is formed on different under-layers including glass plate, silicon oxide, silicon nitride, insulating organic material A (PC403, available from JSR), and insulating organic material B (PC415, available from JSR) by sputter deposition. The average roughness of ITO film having a thickness of 750 Å with different under-layers are shown in Table 1.

TABLE 1

Average Roughness of ITO film having a thickness of 750Å with different under-layers	
Under-layer category	Average roughness (nm)
Glass plate	0.99
Silicon oxide	0.86
Silicon nitride	0.61
Organic material A	3.08

TABLE 1-continued

Average Roughness of ITO film having a thickness of 750Å with different under-layers	
Under-layer category	Average roughness (nm)
Organic material B	3.67
Commercial ITO for PMOLED	0.78

[0027] Average roughness of ITO film having a thickness of 1500 Å with different under-layers are shown in Table 2.

TABLE 2

Average Roughness of ITO film having a thickness of 1500Å with different under-layers	
Under-layer category	Average roughness (nm)
Glass plate	1.36
Silicon oxide	1.47
Silicon nitride	1.27
Organic material A	3.42
Organic material B	3.63

[0028] From Tables 1 and 2, the average roughness (Ra) of ITO film having a thickness of 750 Å on silicon oxide or silicon nitride as under-layer is 0.61 and 0.86 nm respectively, much less than on insulating organic material used as an under-layer with Ra value over 3 nm.

[0029] The average roughness of ITO film having a thickness of 1500 Å with different under-layers produce the same result even though the average roughness of ITO film also depends on the thickness thereof. Accordingly, ITO film formed on dielectric layer is smoother than that formed on insulating organic material layer.

[0030] FIGS. 1a to 1e and FIGS. 2a to 2e are atomic force microscope (AFM) images of ITO film formed on different under-layers and thicknesses. The result indicates the surface images of ITO film on dielectric layers are similar to ITO film without under-layers. On the other hand, the images of ITO film on insulating organic material layers show a much rougher morphology.

[0031] The surface morphology of ITO film formed on different under-layers is further verified by scanning electron microscope (SEM) analysis as shown in FIGS. 3a to 3e and FIGS. 4a to 4e. This shows consistently that the morphology of ITO film is improved by the dielectric layers serving as an under-layer of the transparent electrode, compared. with insulating organic material layers.

[0032] Based on the disclosed results, a new pixel structure having a dielectric layer as an under-layer of a transparent electrode is provided by the present invention to improve luminescent characteristics of AM-OLED.

[0033] The following embodiment is intended to illustrate the invention more fully without limiting its scope, since numerous modifications and variations will be apparent to those skilled in this art.

[0034] FIGS. 5a to 5f are cross-sections illustrating the process flow of forming an AM-OLED according to a preferred embodiment of the present invention.

[0035] First, referring to FIG. 5a, a substrate 10 having a plurality of transistors 20, a gate oxide layer 32, and a buffer layer 30 is provided. The transistor 20 acts as a driver circuit for AM-OLED. Next, a dielectric layer 34 is formed conformally on the buffer layer 30 and the transistor 20 by sputtering, physical vapor deposition (PVD), or plasma enhanced chemical vapor deposition (PECVD). Preferably, the substrate 20 is a transparent insulating material such as glass substrate, plastic substrate, or ceramic substrate. The plastic substrate is polyethylene terephthalate, polyester, polycarbonates, polyacrylates, or polystyrene. To meet the requirements of AM-OLED, the use of thin film transistor (TFT) is preferable, such as amorphous-silicon thin film transistor (a-Si:H TFT), low temperature poly-silicon thin film transistor (LTPS-TFT), or organic thin film transistor (OTFT). Suitable material for the dielectric layer 34 is insulating oxide, nitride, carbide or combinations thereof, such as silicon nitride, silicon oxide, aluminum oxide, magnesium oxide, aluminum nitride or magnesium fluoride.

[0036] Subsequently, referring to FIG. 5b, a first insulating layer 36 is formed conformally on the dielectric layer 34 and electrodes of the transistor 20. Preferably, the material of the first insulating layer 36 is insulating organic material, such as acrylic resin, polyimide, or energy-curable resist.

[0037] Subsequently, referring to FIG. 5c, a first photoresist layer with an opening is formed and defined on the first insulating layer 36. The first insulating layer 36 is etched using the first photoresist layer as a mask, with the dielectric layer 34 acting as an etch stopper. A first insulating layer opening 55 is formed to expose a part of the dielectric layer 34 by etching the first insulating layer 36. A predetermined transparent electrode area is constructed of the first insulating layer opening 55 and the exposed surface of dielectric layer 34. The process of etching the first insulating layer 36 uses wet etching or dry etching.

[0038] Subsequently, referring to FIG. 5d, a transparent electrode 50 serving as the anode electrode of OLED is formed on the predetermined transparent electrode area and the surrounding surface on the first insulating layer 36. Suitable material for the transparent electrode 50 is transparent metal or metal oxide, such as indium tin oxide (ITO), indium zinc oxide (IZO), aluminum zinc oxide (AZO), or zinc oxide (ZnO). Preferably, the transparent electrode 50 is formed by a method such as sputtering, electron beam evaporation, thermal evaporation, or chemical vapor deposition.

[0039] Subsequently, referring to FIG. 5e, a second insulating layer 38 is formed conformally on the transparent electrode. Next, using photolithography and etching with a second resist pattern, the second insulating layer 38 is patterned to expose parts of surface 45 of the transparent electrode. Then, an organic electroluminescent layer 40 is formed conformally on the second insulating layer 38 and the exposed surface 45 of the transparent electrode 50. Preferably, the organic electroluminescent layer 40 is organic semiconductor material, such as small molecule material, polymer, or organo-metallic complex. The organic electroluminescent layer 40 is formed by thermal vacuum evaporation, spin coating, dip coating, roll-coating, injection-fill, embossing, stamping, physical vapor deposition, or chemical vapor deposition.

[0040] Finally, referring to FIG. 5f, a metal electrode 52 serving as the cathode electrode of OLED is formed on the

entire surface of the organic electroluminescent layer 40 by sputtering or evaporation. To meet the requirements of cathode of OLED, material capable of injecting electrons into organic electroluminescent is preferable, for example, low work function material such as Ca, Ag, Mg, Al, Li, or alloys thereof.

[0041] In conventional AM-OLED process, a transparent electrode is formed directly on an insulating organic material. FIG. 6 shows a cross-section of conventional AM-OLED structure. In order to determine the difference between the two, AM-OLED devices with different insulating organic materials (including insulating organic material A (PC403, available from JSR) and insulating organic material B (PC415, available from JSR)) as under-layers of the transparent electrode are also manufactured, and the luminance efficiency of each is measured.

[0042] The luminance efficiency of an AM-OLED device having the dielectric layer (silicon oxide) as the under-layer of the transparent electrode is about 17.2 Cd/m<sup>2</sup>. It is almost the same as the luminance efficiency (17.6 Cd/m<sup>2</sup>) of PM-OLED having a smooth glass plate as under-layer of the transparent electrode. Compared with the luminance efficiency of AM-OLED devices having the insulating organic material layer as under-layer, the luminance efficiency of AM-OLED devices having the dielectric layer as under-layers is obviously higher.

[0043] FIGS. 8a to 8c are scanning electron microscope (SEM) images of different locations of the structure shown in FIG. 7. Accordingly, the morphology of the metal electrode surface 8a with the dielectric under-layer is flattest among those.

[0044] In conclusion, the present invention removes a part of the insulating organic material layer by etching to contact the, transparent electrode directly with the dielectric layer. The surface roughness of the transparent electrode is thus significantly reduced, and therefore the luminance efficiency and reliability of the OLED devices are improved. Furthermore, the pixel structures provided by the present invention prevent current leakage or point discharge, thus avoiding damage to the AM-OLED devices.

[0045] Although the present invention has been described in its preferred embodiments, it is not intended to limit the invention to the precise embodiments disclosed herein. Those who are skilled in the art can still make various alterations and modifications without departing from the scope and spirit of this invention. Therefore, the scope of the present invention shall be defined and protected by the following claims and their equivalents.

What is claimed is:

1. An active matrix organic light emitting display, comprising:

- a substrate with a plurality of thin film transistors;
- a dielectric layer formed over the substrate and the thin film transistors;
- a first insulating layer formed over parts of the dielectric layer to define a predetermined transparent electrode area;
- a transparent electrode formed over the predetermined transparent electrode area;

a second insulating layer formed on both sides of the transparent electrode to expose parts of surface of the transparent electrode;

an organic electroluminescent layer formed over the transparent electrode and the second insulating layer; and

a metal electrode formed over the organic electroluminescent layer.

2. The active matrix organic light emitting display according to claim 1, wherein the substrate is a glass substrate, a plastic substrate, or a ceramic substrate.

3. The active matrix organic light emitting display according to claim 2, wherein the plastic substrate is a transparent insulating material of polyethylene terephthalate, polyester, polycarbonates, polyacrylates, or polystyrene.

4. The active matrix organic light emitting display according to claim 1, wherein the thin film transistors are amorphous-silicon thin film transistors (a-Si:H TFTs), low temperature poly-silicon thin film transistors (LTPS-TFTs), or organic thin film transistors (OTFTs).

5. The active matrix organic light emitting display according to claim 1, wherein the dielectric layer is a layer of insulating oxide, nitride, carbide, or combinations thereof.

6. The active matrix organic light emitting display according to claim 1, wherein the dielectric layer is a layer of indium tin oxide (ITO), indium zinc oxide (IZO), aluminum zinc oxide (AZO), or zinc oxide (ZnO).

7. The active matrix organic light emitting display according to claim 1, wherein the organic electroluminescent layer is a layer of small molecule material, polymer, or organo-metallic complex.

8. A method of forming an active matrix organic light emitting display, comprising:

providing a substrate with a plurality of thin film transistors;

forming a dielectric layer over the substrate and the thin film transistors;

forming a first insulating layer over the dielectric layer;

etching through the first insulating layer with a photoresist layer as a mask to define the exposed surface of the dielectric layer as a predetermined transparent electrode area;

forming a transparent electrode over the predetermined transparent electrode area;

forming a second insulating layer over both sides of the transparent electrode to expose parts of surface of the transparent electrode surface;

forming an organic electroluminescent layer over the transparent electrode and the second insulating layer; and

forming a metal electrode over the organic electroluminescent layer.

9. The method of forming an active matrix organic light emitting display according to claim 8, further comprising, before forming the first insulating layer, flattening the dielectric layer by chemical mechanical polishing.

10. The method of forming an active matrix organic light emitting display according to claim 8, wherein the substrate is a glass substrate, a plastic substrate, or a ceramic substrate.

11. The method of forming an active matrix organic light emitting display according to claim 10, wherein the plastic substrate is a transparent insulating material of polyethylene terephthalate, polyester, polycarbonates, polyacrylates, or polystyrene.

12. The active matrix organic light emitting display according to claim 8, wherein the thin film transistors are amorphous-silicon thin film transistors (a-Si:H TFTs), low temperature poly-silicon thin film transistors (LTPS-TFTs), or organic thin film transistor (OTFTs).

13. The method of forming an active matrix organic light emitting display according to claim 8, wherein the dielectric layer is a layer of insulating oxide, nitride, carbide, or combinations thereof.

14. The method of forming an active matrix organic light emitting display according to claim 8, wherein the dielectric layer is a layer of indium tin oxide (ITO), indium zinc oxide (IZO), aluminum zinc oxide (AZO), or zinc oxide (ZnO).

15. The method of forming an active matrix organic light emitting display according to claim 8, wherein the organic electroluminescent layer is a layer of small molecule material, polymer, or organo-metallic complex.

16. The method of forming an active matrix organic light emitting display according to claim 8, wherein the transparent electrode is formed by sputtering, electron beam evaporation, thermal evaporation, or chemical vapor deposition.

17. The method of forming an active matrix organic light emitting display according to claim 8, wherein the dielectric layer is formed by sputtering, physical vapor deposition (PVD), or plasma enhance chemical vapor deposition (PECVD).

18. The method of forming an active matrix organic light emitting display according to claim 8, wherein the organic electroluminescent layer is formed by thermal vacuum evaporation, spin coating, dip coating, roll-coating, injection-fill, embossing, stamping, physical vapor deposition, or chemical vapor deposition.

\* \* \* \* \*

